

Clamping elements for workbenches

Clamp on workbenches securely and variably



Simply better.



TWV...2K



TWV...K

TWV...H



TW...2K



TW...K

TW...H



Clamping element with variable throat depth TWV

Order-No.	Ø	Clamping height	Throat depth	Rail	kg	qty.	V3
	mm	mm	mm	mm			
TWV16-20-15-2K	16	200	30-150	22 x 8.5	1.12	1	
TWV16-20-15K	16	200	30-150	22 x 8.5	1.04	1	
TWV16-20-15H	16	200	60-150	22 x 8.5	1.21	1	

Clamping element with fixed throat depth TW

Order-No.	Ø	Clamping height	Throat depth	Rail	kg	qty.	V3
	mm	mm	mm	mm			
TW16-20-10-2K	16	200	100	22 x 8.5	0.93	1	
TW16-20-10K	16	200	100	22 x 8.5	0.86	1	
TW16-20-10H	16	200	100	22 x 8.5	1.01	1	

- Precise, individual clamping
- Tempered profile and sliding arm for sprung and elastic clamping
- Infinitely adjustable throat depth (TWV)

Various design versions:

- High quality 2-component plastic handle and tommy bar with rounded ends – each with smooth-running trapezoidal threaded spindle and tool-free pressure plate replacement
- Lever handle with an indexing mechanism for controlled, fast and vibration-proof

3D CAD data in the download area of the BESSEY website

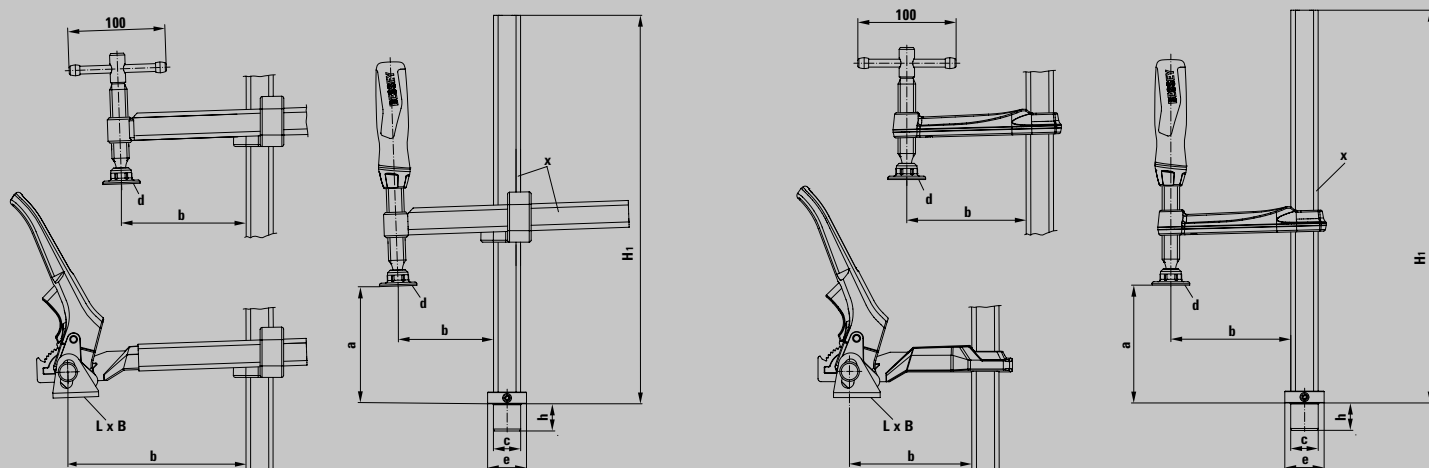

Table of dimensions

	Bolt Ø	Bolt height	Clamping height	Throat depth	Height of base	Pressure plate dimensions		Foot "F"		Rail profile
	"c"	"h"	"a"	"b"	"H1"	"L x B"	Ø "d"	Foot Ø "e"	Foot height	"x"
	mm	mm	mm	mm	mm	mm	mm	mm	mm	mm
TWV16-20-15-2K	16	20,5	200	30-150	265	–	32	30	10	22 x 8.5
TWV16-20-15K	16	20,5	200	30-150	265	–	32	30	10	22 x 8.5
TWV16-20-15H	16	20,5	200	60-150	265	41 x 26	–	30	10	22 x 8.5
TW16-20-10-2K	16	20,5	200	100	265	–	32	30	10	22 x 8.5
TW16-20-10K	16	20,5	200	100	265	–	32	30	10	22 x 8.5
TW16-20-10H	16	20,5	200	100	265	41 x 26	–	30	10	22 x 8.5

Clamping elements for workbenches

Clamp on workbenches securely and variably



Simply better.



Easily and quickly to use

BESSEY clamping elements of the TWV16 and TW16 series can be used with just a few turns on all standard workbenches:

- due to the connection of the **TW16AW workbench adapter** – available in 3 sizes suitable for 19 mm, 20 mm and 30 mm hole diameter
- due to replaceable bolts on the adapter for the use of further hole systems

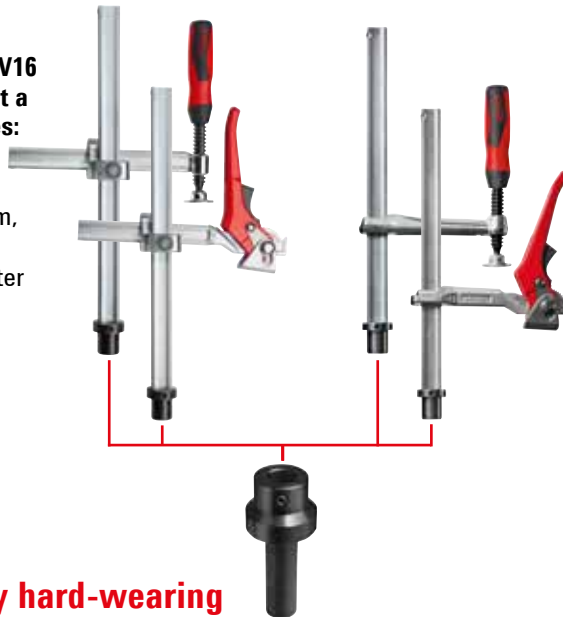

Precise and safe

BESSEY always offers the right clamping element for different requirements:

- due to **2 throat depth variants**: either with infinitely adjustable (TWV) or fixed throat depth (TW)
- due to **3 handle variations**: the 2-component plastic handle and tommy bar – each with smooth-running trapezoidal threaded spindle and tool-free pressure plate replacement – and lever handle with an indexing mechanism for controlled, fast and vibration-free clamping

Robust and highly hard-wearing

The tried-and-tested BESSEY all-steel clamp solutions were the inspiration for the development of the clamping elements and guarantee a form-stable and torsion-free tool:

- due to the unique **BESSEY steel quality**, which is available in the optimized profile shape as well as the easy-going spindle
- due to the particularly **hard-wearing steel cams at the lever handle**

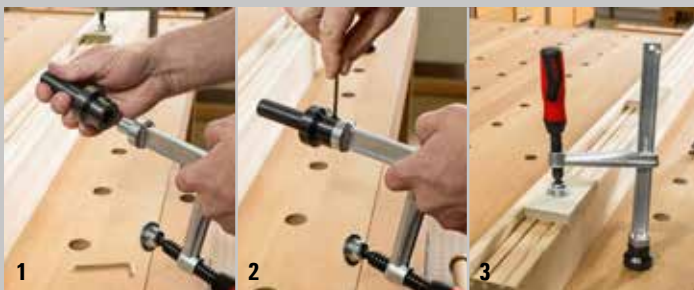

Workbench adapter TW16AW

Order-No.	∅	Suitable for		⚖️	📦	V3
	mm	mm	"	kg	qty.	
TW16AW19	16	19	3/4	0.33	10	
TW16AW20	16	20	13/16	0.34	10	
TW16AW30	16	30	1 3/16	0.52	10	

For further information
www.bessey.de



BESSEY Tool GmbH & Co. KG ■ Mühlwiesenstr. 40
 74321 Bietigheim-Bissingen, Germany
 Fon +49 7142 401-0 ■ Fax +49 7142 401-452
 E-Mail: tool-info@bessey.de ■ www.bessey.de

Your dealer: