

SIMPLY BETTER.

Self-adjusting toggle clamps range

BESSEY



With self-adjusting opening fix quickly



**Even more flexible clamping
up to 5-times faster**

Uncompromisingly versatile
One size of the BESSEY toggle clamp replaces multiple competitor sizes simultaneously:

- due to an extremely large clamping range, thanks to the patented mechanism



Teaser >



Ready to go – the first time and for quick set-up during workpiece changes
BESSEY STC toggle clamps adapt to workpieces of varying thickness – without manual setting of the spindle and, with practically the same clamping force:

- due to an automatic clamping width range

Powerful and gentle
Even sensitive workpieces, e. g. with veneered or varnished surfaces, can be gently clamped:

- due to moving pressure plate with removable protective cap
- due to clamping force regulation via adjustment screw in the joint





Vertical toggle clamp with open arm and horizontal base plate STC-VH



STC-VH20



STC-VH50

Order number	Opening	Automatic adjustment	Clamping force	Weight	PU	
	mm	mm	appr. N	kg	qty.	V3
STC-VH20	35	20	1,100	0.22	6	
STC-VH50	40	35	2,500	0.43	6	

3D CAD data at
["https://bessey.partcommunity.com"](https://bessey.partcommunity.com),
["https://www.traceparts.com"](https://www.traceparts.com)
 and in the download area of the BESSEY website



You will find accessories on page 6/7

- Lever is in vertical clamping position
- Automatic, seamless adjustment of the clamping height up to 35 mm with almost constant clamping force – without manual changing of the pressing screw position
- Adjustable clamping force up to 2,500 N, based on the adjusting screw in the joint
- Sturdy, tempered sheet steel for longer service life
- Base plate hole pattern suitable for millimetres and inches
- High-quality, oil-resistant two-component plastic handle

Table of dimensions

		L1	L2	L3	L4	L5	L6	L7	L8	L9	H1	H2	H3	H4	H5	H6	B1	B2	B3	B4	Lo1	Lo2	Lo3	Lo4	Ø
STC-VH20	mm	92	50	20	18.7	-	43	35	60	123	41	100	10	42	129	-	10	6	24	48	26	13	28	27-32	5.5
	"	3.62	1.97	0.79	0.74	-	1.69	1.38	2.36	4.84	1.61	3.94	0.39	1.65	5.08	-	0.39	0.24	0.94	1.89	1.02	0.51	1.10	1.06-1.25	0.22
STC-VH50	mm	116	63	40	24.6	-	53	44	76	154	52	126	14	50	162	-	13.25	8.25	30	60	25.4	25.4	40	33-48	6.5
	"	4.57	2.48	1.57	0.97	-	2.09	1.73	2.99	6.06	2.05	4.96	0.55	1.97	6.38	-	0.52	0.32	1.18	2.36	1.00	1.00	1.57	1.30-1.89	0.26

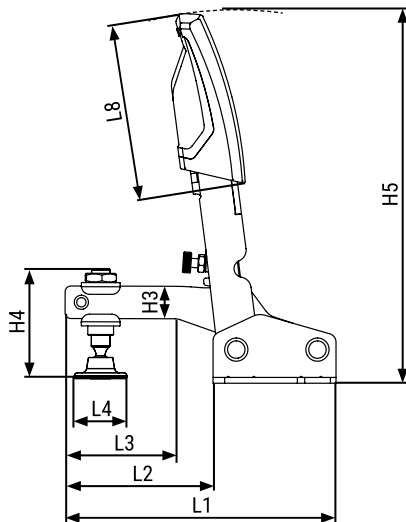

STC-VH50

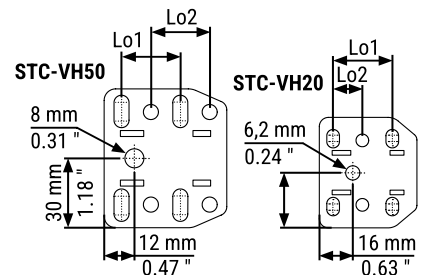
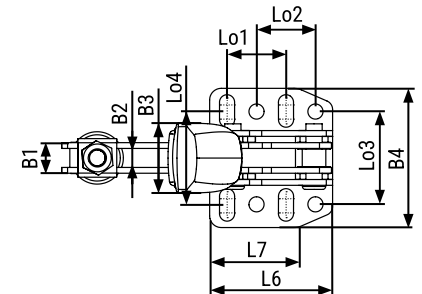
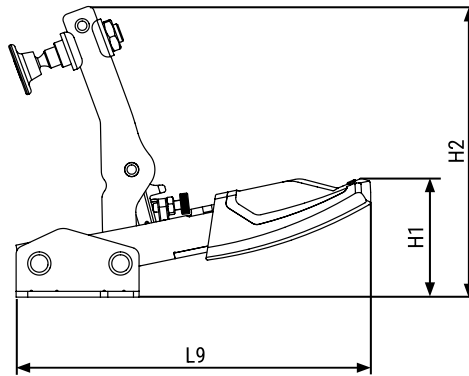

With self-adjusting opening fix quickly



Horizontal toggle clamp with open arm and horizontal base plate STC-HH



STC-HH20

STC-HH50

STC-HH70

Order number	Opening mm	Automatic adjustment mm	Clamping force appr. N	Weight kg	PU qty.	V3
STC-HH20SB	35	20	1,100	0.20	3	
STC-HH50	40	35	2,500	0.38	6	
STC-HH50SB	40	35	2,500	0.38	3	
STC-HH70	60	35	2,500	0.42	6	
STC-HH70SB	60	35	2,500	0.42	3	

3D CAD data at
["https://bessey.partcommunity.com"](https://bessey.partcommunity.com),
["https://www.traceparts.com"](https://www.traceparts.com)
 and in the download area of the BESSEY website



You will find accessories on page 6/7

- In the clamped position, the lever is horizontal
- Automatic and infinitely variable adjustment of the clamping height up to 35 mm while clamping force remains unchanged – without having to make manual changes to the position of the pressure screws
- Clamping force is variable up to 2,500 N depending on the adjustment of the set screw in the cantilevered joint
- Sturdy, tempered metal sheets for a long service life
- Hole pattern on the base plate designed to facilitate fast and secure clamping set-up for metric and imperial
- High-quality oil resistant two-component plastic handle

SB = On carded hang pack

Table of dimensions

		L1	L2	L3	L4	L5	L6	L7	L8	L9	H1	H2	H3	H4	H5	H6	B1	B2	B3	B4	Lo1	Lo2	Lo3	Lo4	Ø
STC-HH20	mm	169	58	39	18.7	91	43	32	50	-	38	125	11	42	22	-	10	6	26	48	25.7	12.7	28	27 - 32	5.5
	"	6.65	2.28	1.54	0.74	3.58	1.69	1.26	1.97	-	1.50	4.92	0.43	1.65	0.87	-	0.39	0.24	1.02	1.89	1.01	0.50	1.10	1.06 - 1.25	0.22
STC-HH50	mm	217	77	40	24.6	113	53	38	72	-	47	158	14	50	27	-	13	8	32	60	25.4	25.4	38	33 - 48	6.5
	"	8.54	3.03	1.57	0.97	4.45	2.09	1.50	2.83	-	1.85	6.22	0.55	1.97	1.06	-	0.51	0.31	1.26	2.36	1.00	1.00	1.50	1.30 - 1.89	0.26
STC-HH70	mm	217	77	40	24.6	113	53	38	72	-	64	175	14	68	44	-	13	8	32	60	25.4	25.4	38	33 - 48	6.5
	"	8.54	3.03	1.57	0.97	4.45	2.09	1.50	2.83	-	2.52	6.89	0.55	2.68	1.73	-	0.51	0.31	1.26	2.36	1.00	1.00	1.50	1.30 - 1.89	0.26

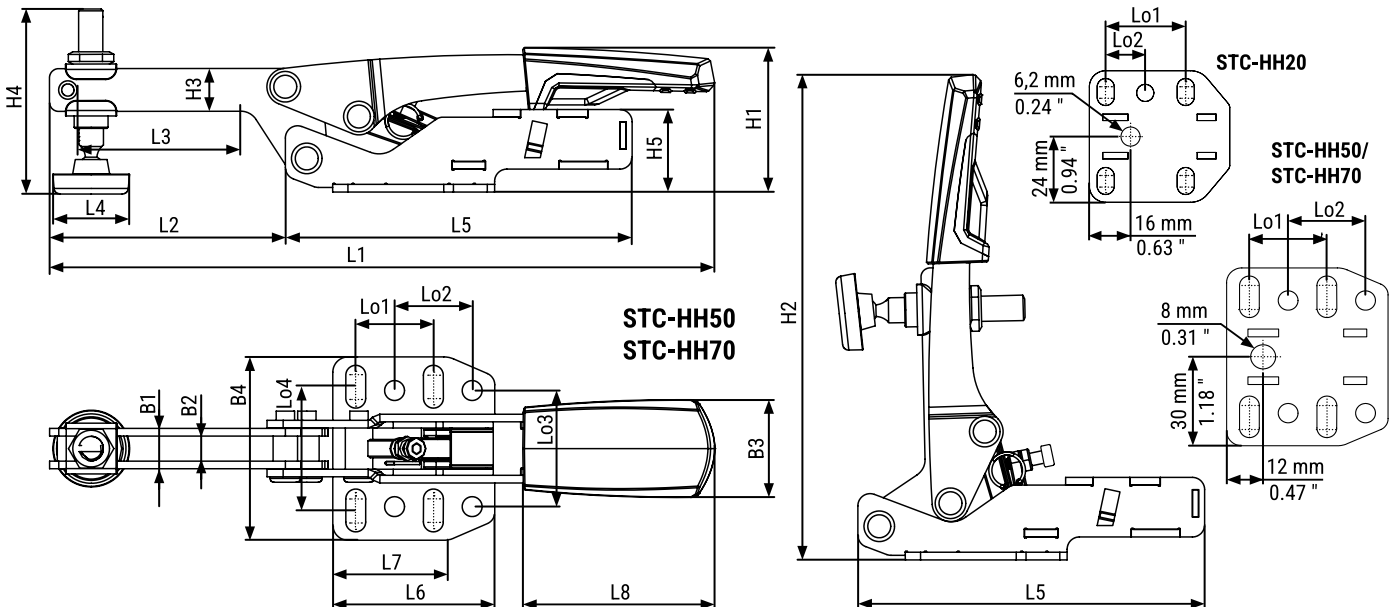



**Push/pull clamp with horizontal base plate
STC-IHH**

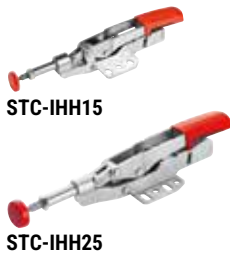

Order number	Opening	Automatic adjustment	Clamping force	Weight	PU	
	mm	mm	appr. N	kg	qty.	V3
STC-IHH15	25	8	1,100	0.19	6	
STC-IHH25	35	13	2,500	0.45	6	
STC-IHH25SB	35	13	2,500	0.46	3	

3D CAD data at
["https://bessey.partcommunity.com"](https://bessey.partcommunity.com),
["https://www.traceparts.com"](https://www.traceparts.com)
 and in the download area of the BESSEY website



You will find accessories on page 6/7

- Moving the handle moves the push-pull rod
- Automatic and infinitely variable adjustment of the clamping height up to 13 mm while clamping force remains unchanged – without having to make manual changes to the position of the pressure screws
- Adjustable clamping force up to 2,500 N, based on the adjusting screw in the joint
- Sturdy, tempered metal sheets for a long service life
- Base plate hole pattern suitable for millimetres and inches
- High-quality oil resistant two-component plastic handle

SB = On carded hang pack

Table of dimensions

		L1	L2	L3	L4	L5	L6	L7	L8	L9	H1	H2	H3	H4	H5	H6	B1	B2	B3	B4	Lo1	Lo2	Lo3	Lo4	Ø
STC-IHH15	mm	178	-	-	18.7	122	43	32	50	-	36	122	-	-	20	21.6	8.5	-	26	48	25.7	12.7	28	27-32	5.5
	"	7.01	-	-	0.74	4.80	1.69	1.26	1.97	-	1.42	4.80	-	-	0.79	0.85	0.33	-	1.02	1.89	1.01	0.50	1.10	1.06-1.25	0.22
STC-IHH25	mm	233	-	-	24.6	154	53	38	73	-	46	155	-	-	25	27	12	-	32	60	25.4	25.4	38	33-48	6.5
	"	9.17	-	-	0.97	6.06	2.09	1.50	2.87	-	1.81	6.10	-	-	0.98	1.06	0.47	-	1.26	2.36	1.00	1.00	1.50	1.30-1.89	0.26

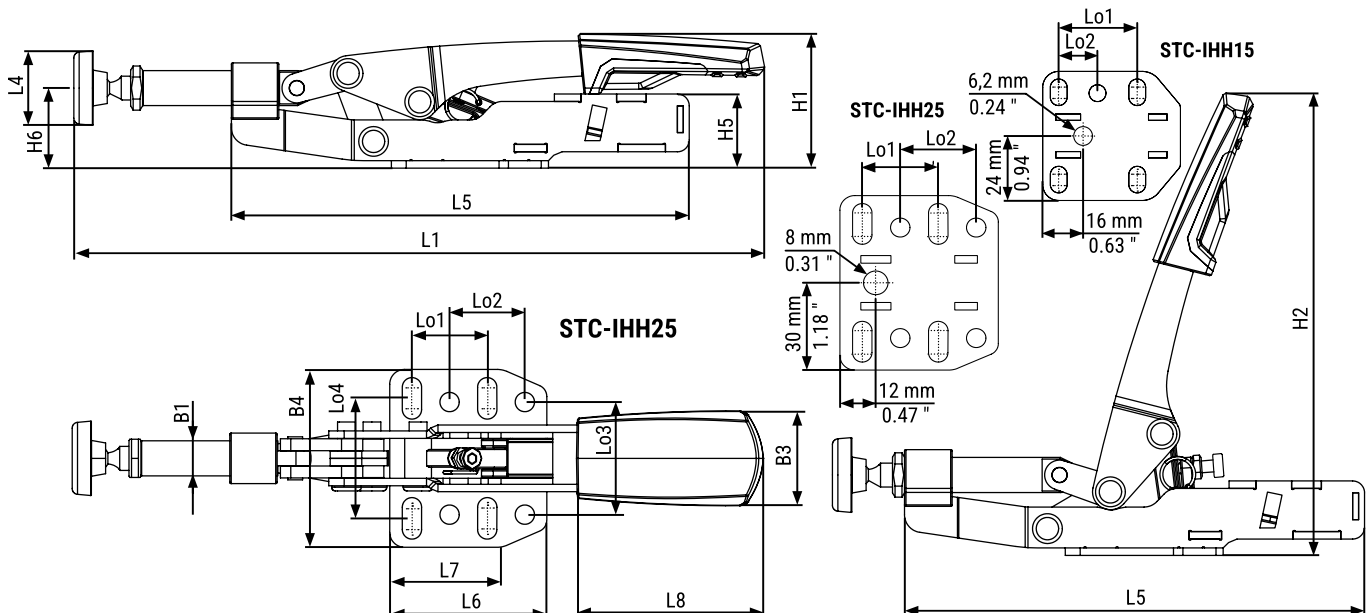

Accessories for use on mobile tables



STC accessory set and adapter for multifunction tables



Order number	Contents/ pc.	Opening mm	Automatic adjust- ment mm	Clamp- ing force N	Weight		PU	V3
					kg	qty.		
STC-HH50-T20	1 x STC-HH50 + 1 x STC-SET-T20	40	35	2,500	0.47	1		
STC-HH70-T20	1 x STC-HH70 + 1 x STC-SET-T20	60	35	2,500	0.51	1		
STC-IHH25-T20	1 x STC-IHH25 + 1 x STC-SET-T20	35	13	2,500	0.54	1		
STC-VH50-T20	1 x STC-VH50 + 1 x STC-SET-T20	40	35	2,500	0.52	1		
Order number	Contents/ pc.	Suitable for		Weight		PU	V3	
		kg	qty.					
STC-SET-T20	1 x Cylindrical screw DIN 912 M 8 x 35 1 x Lock pin D 20 x 17 1 x Knurled nut M 8	STC-HH50 STC-HH70 STC-IHH25 STC-VH50	0.09	50				

- For using the BESSEY toggle clamps on multifunction tables such as Festool MFT and Sortimo WorkMo with hole diameter of 20 mm and plate thickness of min. 19 mm to max. 25 mm

Toggle clamp systainer STC-S-MFT



Order number	Contents/ pc.	Weight		PU	V3
		kg	qty.		
STC-S-MFT	4 x horizontal toggle clamp STC-HH50 2 x push-pull toggle clamp STC-IHH25 6 x adapter STC-SET-T20 2 x all-steel table clamp GTR12	5.71	1		

- Multi-functional systainer for installation technicians
- With wood insert including 20 holes
- And 3 different clamping options

Accessories for use on welding tables



Toggle clamp adapter TWA-STC



TW16A-STC



TW28A-STC



Order number	Hole Ø	Suitable for	Thread	Weight	PU	
	mm			kg	qty.	V3
TW16A-STC	16	STC-HH STC-IHH STC-VH	M5	0.19	1	
TW28A-STC	28		M6	0.28	1	

3D CAD data in the download area of the BESSEY website

- Accessory for BESSEY STC toggle clamp with horizontal base plate
- With bolt – for use directly on the welding table
- Without bolt – for screwing to the extension TWX

Extension TWX



TWX



TWX + TWA-STC + STC-HH



Order number	Hole Ø	Suitable for	Adjusting range	Weight	PU	
	mm		mm	kg	qty.	V3
TW16X	16	TW16A-STC TW16VAD TWWAD	15-200	0.41	1	
TW28X	28	TW28A-STC TW28VAD TWWAD TW28AV	15-300	1.76	1	

3D CAD data in the download area of the BESSEY website

- Accessory for BESSEY toggle clamp adapter TWA-STC, TWVAD and TW28AV
- Lowering of round workpieces is infinitely adjustable using the adjusting ring in the table

Clamping tools and Cutting tools by professionals for professionals



When it comes to innovative solutions for clamping and fixing workpieces and cutting sheet metal, this is the right place. No matter if classic clamps, traditional sheet metal snips or special solutions are required for special work requirements, BESSEY offers the right clamping and cutting tool for every craftsman in wood and metalworking in order to optimally support it in its work.



Detailed information
about all products at
www.bessey.de/en-gb

Clamping tools



All-steel screw clamps



Parallel clamps



Metal angle clamps



Door frame assembly tools

Cutting tools



Compound leverage snips

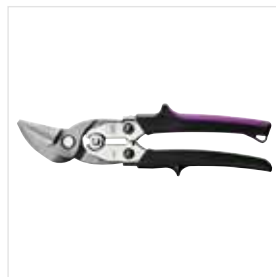

High-performance snips
with HSS edges

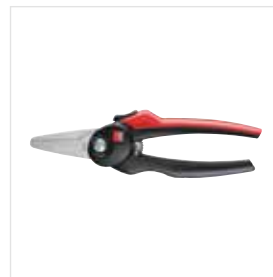

Multi-purpose cutters



Folding utility knives
and multitool

BESSEY
Imagefilm



BESSEY Tool GmbH & Co. KG ■ Mühlwiesenstraße 40
74321 Bietigheim-Bissingen, Germany
Fon +49 7142 401-0 ■ Fax +49 7142 401-452
E-Mail: tool-info@bessey.de

Your dealer:

More information
www.bessey.de

